

SONY

3CCD COLOR CAMERA MODULE

XC-003/003P

1/3" CCD

003:768(H) x 494(V)

003P:752(H) x 582(V)

Component/OEM



OUTLINE

The XC-003/003P is a compact 3CCD RGB color camera module designed for machine vision and image processing applications.

The introduction of a 1/3-inch CCD prism block enables the XC-003/003P to use with the standard C mount lens that is widely used in connection with an industrial camera.

The use of a C mount lens not only enables the selection of various lenses but also facilitates the installation of an optical instrument such as a microscope. The XC-003/003P has no RGB shift because of Co-Site Sampling System, which captures picture information accurately. Since each R/G/B signals has 768 x 494(NTSC)/752 x 582(PAL) pixels, the XC-003/003P horizontal resolution reaches three times as high as that of a conventional 1CCD color camera (Sony's XC-711). Thus, the picture that is excellent in resolution and in color reproducibility of the XC-003/003P can be used in the visual inspection system as well as image processing. Additionally the RGB signal is controllable by inputting external HD/VD pulses.

For obtaining a frame still image of moving object a strobe is useful, and for a field still image, E-DONPISHA®, an asynchronous trigger shutter function is convenient. These functions can be used for inspecting crack of printed matter, fruits and vegetables, semiconductor wafers, and LCD color filter.

FEATURES

- 3CCD C-mount
- Co-Site Sampling
- 1/3" Hyper HAD CCD
- High resolution 570 TV lines, RGB 756/739 pixels each
- RGB, Y/C, and VBS signals can be output simultaneously.
- HD/VD or VS external sync available
- E-DONPISHA®-Asynchronous shutter
- Internal sync Restart Reset
- One push, automatic white balance
- On-Screen Menu
- Color-Bar
- Small, one package 50(H) x 56(W) x 128(D) mm

PRODUCT COMPOSITION

STANDARD LENS

VCL-08WM
F2.2 8mm

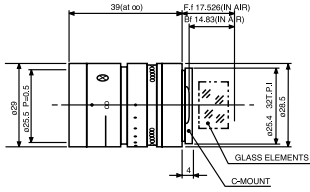

Focal length	8mm
F number	1:2.2
Aperture	F2.2-F16,close
Back focus	14.83mm (in air)
Flange back focal distance	17.526mm (in air)
Mount	C Mount
Min.distance to object	100mm from lens front
Picture area at min.distance	66(H)mm x 50(V)mm
Comprehensive	33.24'(H) x 25.22'(V)
Filter size	M25.5 x P0.5
Outward dimensions	ø29x 39mm
Weight	60g

VCL-16WM
F2.2 16mm

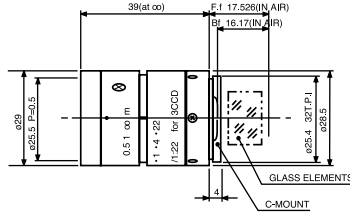

Focal length	16mm
F number	1:2.2
Aperture	F2.2-F16,close
Back focus	16.17mm (in air)
Flange back focal distance	17.526mm (in air)
Mount	C Mount
Min.distance to object	100mm from lens front
Picture area at min.distance	34(H)mm x 26(V)mm
Comprehensive	17.04'(H) x 12.50'(V)
Filter size	M25.5 x P0.5
Outward dimensions	ø29x 39.8mm
Weight	60g

VCL-25WM
F2.2 25mm

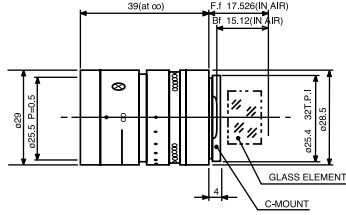

Focal length	25mm
F number	1:2.2
Aperture	F2.2-F16,close
Back focus	15.12mm (in air)
Flange back focal distance	17.526mm (in air)
Mount	C Mount
Min.distance to object	200mm from lens front
Picture area at min.distance	42(H)mm x 32(V)mm
Comprehensive	10.58'(H) x 8.14'(V)
Filter size	M25.5 x P0.5
Outward dimensions	ø29x 39mm
Weight	60g

CAMERA MODULE

XC-003/003P



CAMERA CABLE

- (12pin-12pin)
CCXC-12P02S(2m)
-12P05S(5m)
-12P10S(10m)
-12P25S(25m)
-12P05D(DOWN)
-12P05U(UP)
-12P05R(RIGHT)
-12P05L(LEFT)



RGB CABLE

- (9pin D SUB-BNC)
CCXC-9DB(5m)



- (9pin D SUB-9pin D SUB)
CCXC-9DD(5m)



EXTENSION RING KIT

- LO-77ERK
ø30 0.5, 1, 5, 10, 22mm



- 50MM MACRO LENS
F2.8 50mm



ND FILTER

LO-37ND

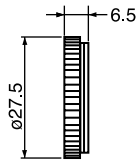

Used in the excessively light open air

ND : 64

MACRO LENS

- 45MM MACRO LENS
F3.2 45mm

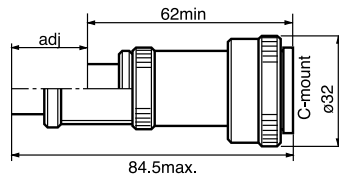

Magnification(x1-x0.5) f=45mm
Close-up(75mm-120mm)
Effective F number(F6.4-F5.1)
The 45MM MACRO LENS is a compact and lightweight unique macro lens that is used to shoot an object of about 5.6x7.5mm from a distance of about 100mm.

ZOOM LENS



- CANON(x6)
J6 x 11-1.4-II
- FUJINON
T6 x 6.5DB-SNDS71(x6)
T10 x 6DB-SNDS71(x10)

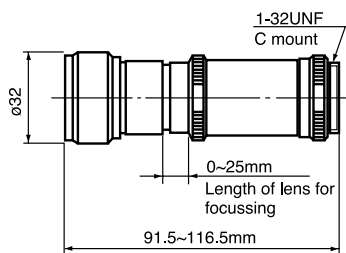

Magnification(x1.2-x0.8) f=50mm
Close-up(91.7mm-112.5mm)
Effective F number(F6.16-F5.04)
The 50MM MACRO LENS is a compact and lightweight high-vision macro lens that is used to shoot an object of about 4.5x 6mm from a distance of about 100mm. This lens has a resolution of 1000 TV lines.

Color Shading

Generally an image taken by 3CCD camera with a prism block shows white shading in the upper and lower positions on the screen due to diachronic coating. To improve this, close the lens iris as far as possible, or use a lens with the exit pupil distance longer than 100mm.

Applicable Lenses

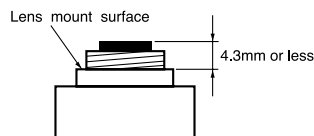

Lens Selection

f(mm)=4.8x Distance from the object (mm)
Focal distance Width of the object (mm)

Microscope

JUNCTION BOX

JB-77



CAMERA ADAPTOR

DC-777/777CE



DC-77RR/77RRCE



This adaptor outputs a VBS signal in two channels. It also has the through terminal of a sync signal.

CONNECTIONS

●SIDE PANEL

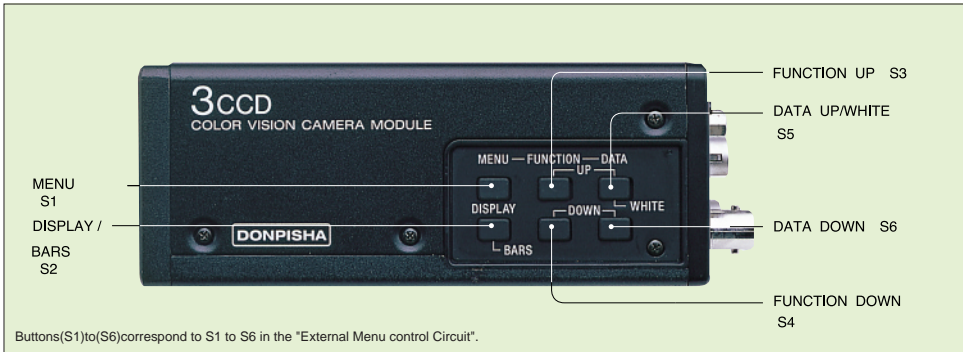

Buttons(S1)to(S6)correspond to S1 to S6 in the "External Menu control Circuit".

If you press this button while shooting a white object,the white balance is adjusted automatically,and its value is stored in the camera's memory.

●MENU:On Screen

PAGE 1	
> GAIN	00DB
C.TEMP	3200K
WHT BAL	AUTO
SHUTTER	OFF
FRM/FLD	FRM

PAGE 2	
H.PHASE	00
GAMMA	OFF
DTL	ON(*)
G.SYNC	OFF
GENLOCK	NORMAL
D-SUB	VBS

*.DTL function is available only for VBS and Y/C.

●REAR PANEL

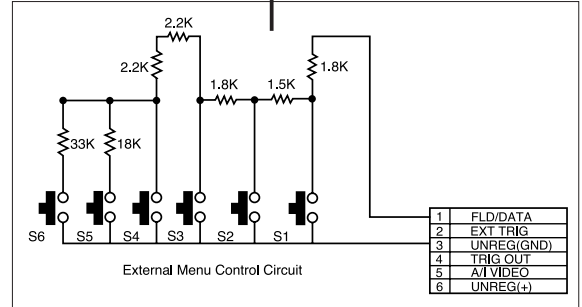
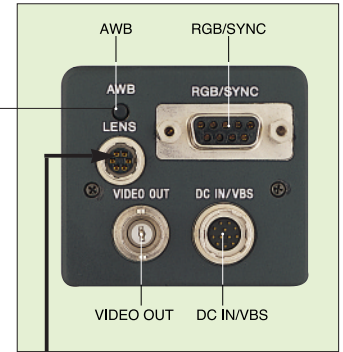

●DC IN/VBS(12 pin)

Pin no.	External sync		Internal sync
	HD/VD	VS	
1	Ground	Ground	Ground
2	+12V	+12V	+12V
3	Video output(ground)	Video output(ground)	Video output(ground)
4	Video output(signal)	Video output(signal)	Video output(signal)
5	HD input(ground)	—	HD output(ground)
6	HD input(signal)	—	*/ HD output(signal) ^{a)}
7	VD input(signal)	VS input(signal)	*/ VD output(signal) ^{a)}
8	—	—	*/ Clock output(ground) ^{b)}
9	—	—	*/ Clock output(signal) ^{b)}
10	Ground	Ground	Ground
11	+12V	+12V	+12V
12	VD input(ground)	VS input(ground)	VD output(ground)

a) You need to change the internal switch settings for HD and VD outputs.
 b) The clock output is not set when at factory setting. Soldering is required in order for clock output.
 The clock signal is about 400m Vp-p.

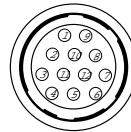

●3CCD OPTICAL BLOCK

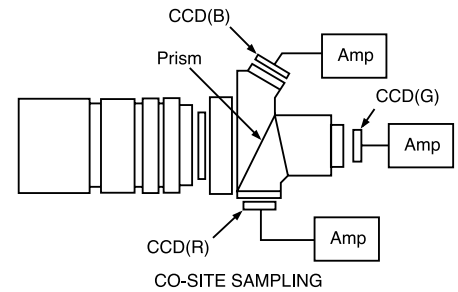

●RGB/SYNC (D SUB, 9pin)

Outputs RGB and sync signals. Use the CCXC-9DB/CCXC-9DD Cable(neither supplied).

Pin no.	Signal
1	VBS output(ground)
2	RGB output(ground)
3	R output
4	G output
5	B output
6	VBS/Y output
7	SYNC output(signal)
8	SYNC output(ground)
9	-/C output



●LENS(6pin)

Used for connecting the auto-iris lens, or used for external trigger input and WEN output if using the E-DONPISHA® or Restart Reset functions.

Pin no.	Signal
1*	FLD/DATA
2	External trigger input
3	Ground
4	WEN output
5	Video signal output
6	+12V



* Field index pulse output/External menu control.

●CONNECTION DIAGRAM

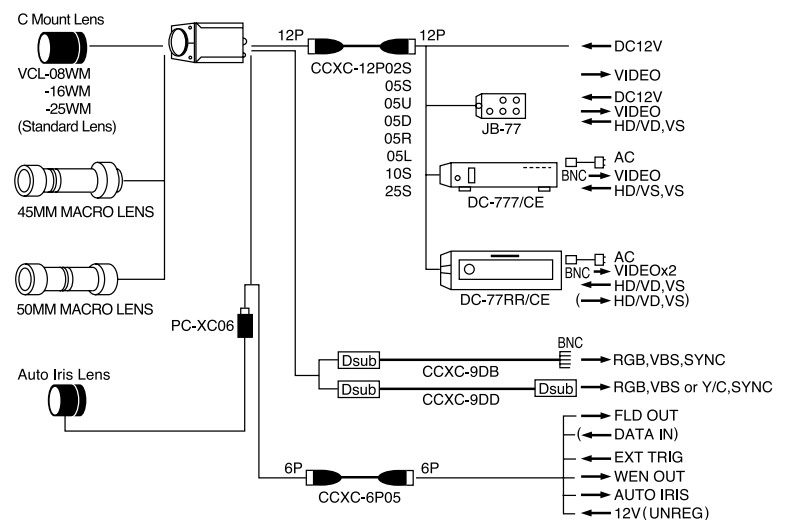

INTERNAL SWITCH

Switch	Function	Setting	Contents	Factory Setting
S1	R/B SYNC	ON	If G,SYNC is set to ON, sync signals are added to all RGB signals. If G,SYNC is set to OFF, sync signals are not added.	OFF
		OFF	Sync signals are not added to the RGB signals.	
S101	HD/VD sync mode selection	EXT	External sync signal is acceptable.	EXT
		INT	Resets to internal sync mode. HD/VD signals are output.	
S102	75Ω termination switch	ON	The input external sync signal is terminated at 75Ω on this camera.	ON
		OFF	The input external sync signal is terminated at 75Ω on the last camera connected.	
S201-1	FLD OUT/DATA IN	ON	The field index is output.	ON
		OFF	Lets you control the on-screen menu.	
S201-2	Interlace/non-interlace	ON	Image output signals are scanned without using interface. You can continue to output image signals for field I only.	OFF
		OFF	Image output signals are scanned using interface.	
S201-3	WEN pulse phase switch	ON	Output a I vertical period amplitude for the image signal period.	ON
		OFF	Outputs before the image signal.*	
S201-4	Image output signal phase switch	ON	The image signal is output at 3V from the external trigger.	OFF
		OFF	The image signal is output immediately after the external trigger.	

* Amplitude differs according to external trigger.

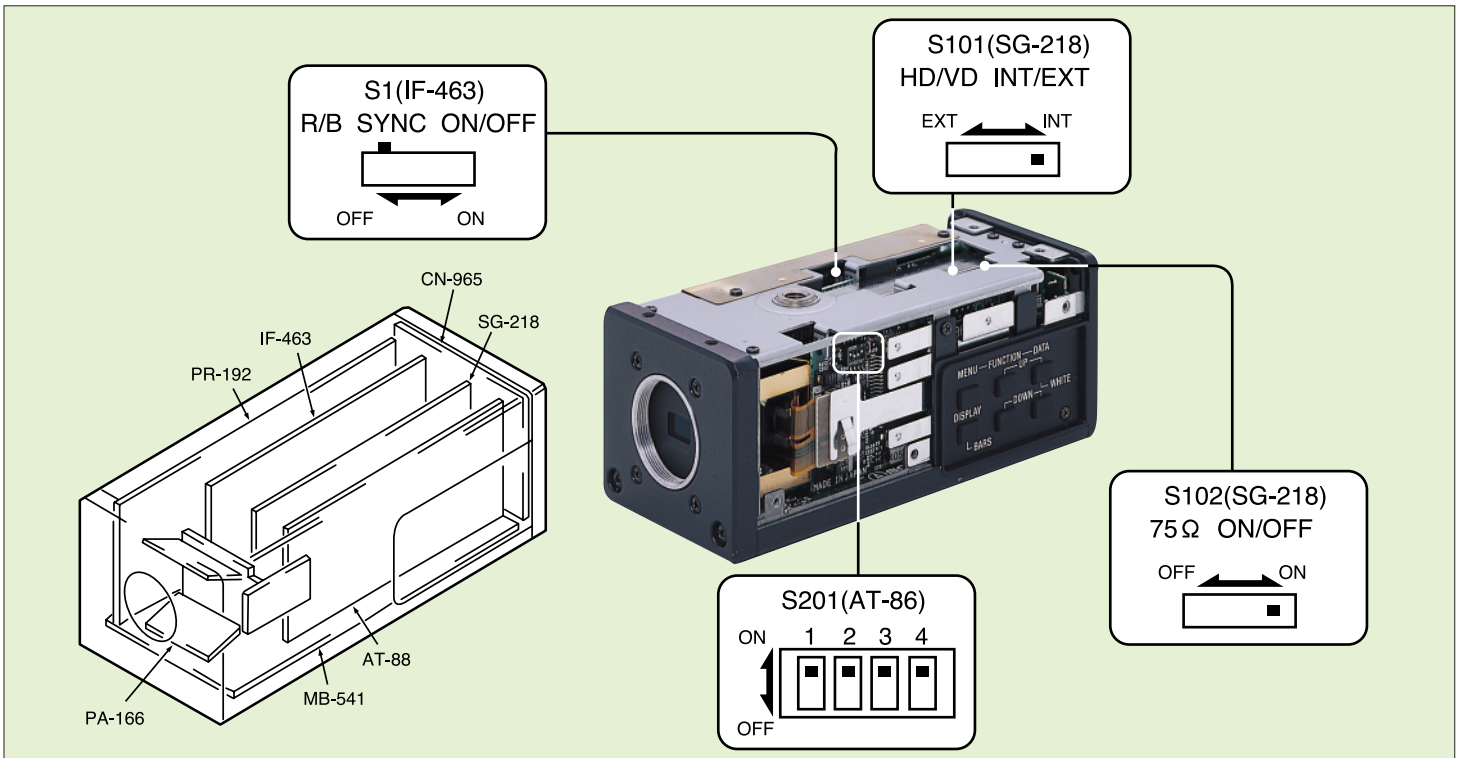

SETTING OPERATION MODE BY JUMPER

The setting of the camera can be changed by the solder jumpers on the SG-218 board.

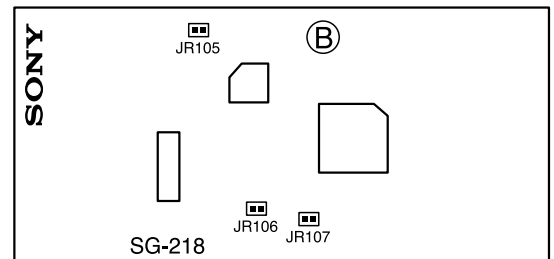

Jumper	Function	Setting	Description	Factory Setting
JR105	CLOCK Output	Open	CLOCK signal is not output.	Open
		Short	CLOCK signal is output.	
JR106	E-DONPISHA® Mode	Open	Reset mode	Open
		Short	Nonreset mode.	
JR107	WEN Pulse Polarity Change	Open	WEN pulse is output as a negative.	Open
		Short	WEN pulse is output as a positive.	

E-DONPISHA®

E-DONPISHA® function

The E-DONPISHA function is used to read a field still picture in arbitrary timing without stopping any moving object. The delay time between the trigger input and exposure start is approximately 2 μs, and an instantaneous picture can be obtained without missing the shot timing.

The still picture obtained using an external trigger signal is always used as the information that is read from the odd-line gate of CCD.

The field accumulation mode in which the sensitivity becomes double is selected because an electronic shutter is used.

NON RESET mode

A continuous composite sync signal is contained in the trigger standby video signal. The vertical synchronization of the video signal is not disturbed by the trigger input signal. However, the video sync signal by the trigger output is undefined. (odd/even)

External synchronization can be used.

A video output timing pulse is used as the second vertical sync signal after a trigger pulse is input.

The operating mode is selected when solder jumper JR106 on the SG-218 board is set from open to short.

RESET mode

A continuous composite sync signal is contained in the trigger standby video signal. When a trigger pulse is input, the composite sync signal is reset and the vertical synchronization is disturbed. Therefore, only internal synchronization is used.

The sync signal of a trigger output video signal is always used as the first field (odd) picture.

RESET modes (1) and (2) are selected by the output timing of a video signal.

RESET mode (1)

The timing pulse of a video output signal is used as the first vertical sync signal immediately after a trigger pulse is input. Therefore, the operating mode in this case is fastest in the E-DONPISHA® function. This mode is set at the factory.

RESET mode (2)

The timing pulse of a video output signal is used as the third vertical sync signal after a trigger pulse is input.

The operating mode is selected when switch S201-4 on the AT-86 board is set from OFF to ON.

WEN

A WEN (WRITE ENABLE) pulse is output from the camera so as to notify of the write timing of a video output signal after a trigger pulse is input.

The WEN pulse has two types of timing. The timing is selected by switch S201-3 on the AT-86 board. The polarity can also be selected by solder jumper JR107 on the SG-218 board.

E-DONPISHA(NON RESET MODE)

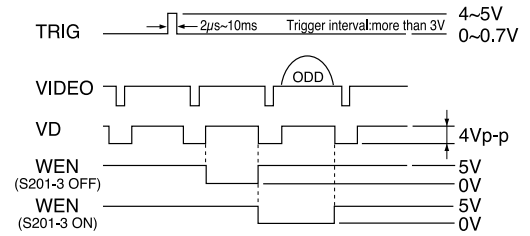

E-DONPISHA(RESET MODE(1))

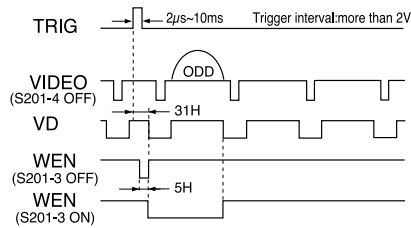

E-DONPISHA(RESET MODE(2))

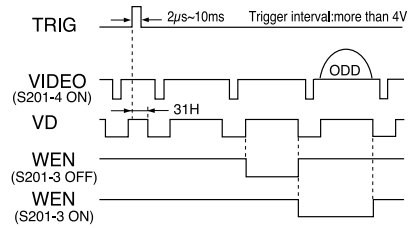

INTERNAL SYNC RESTART RESET

Restart Reset of internal synchronization

The Restart Reset functions are used to generate a timing pulse using a trigger signal and obtain the frame or field picture of a still subject. A long-time exposure picture is also obtained by lengthening the interval of a trigger signal. For the conventional Restart Reset functions, continuous horizontal drive signals (HD) and 2 to 4 vertical drive signals (VD) must be input to the camera. For new Restart Reset functions, a sync signal can be generated inside the camera using an external trigger signal. These functions make the operation easy.

The number of VD signals to be generated inside the camera is 1 to 4. This mode can be set in a camera menu. The first picture after a trigger pulse is input is saturated, so use the second picture. The picture after a trigger pulse is input is interlaced from the first field (odd) picture.

R.R 1 mode

One VD signal is generated for a trigger pulse.

A picture is used as the first field (odd) picture.

Two trigger pulses are input, and the standby time required until the second trigger pulse is input corresponds to the exposure time. A long-time exposure field picture is obtained by lengthening the interval of a trigger signal.

R.R 2 mode

Two VD signals are generated for a trigger pulse.

The second field (even) picture that is output later is used in these modes. The sensitivity becomes double in case of use in the field accumulation.

R.R 3 mode

Three VD signals are generated for a trigger pulse.

The second field (even) picture that is output secondly and the first field (odd) picture that is output thirdly are used in these modes.

These modes are used for field accumulation interlacing.

R.R 4 mode

Four VD signals are generated for a trigger pulse.

The first field (odd) picture that is output thirdly and the second field (even) picture that is output fourthly are used in these modes.

A picture is interlaced for frame accumulation, and a vertical resolution of 485(575) lines are obtained.

When two trigger pulses are input and the interval of the second trigger pulse is lengthened, the first frame picture of the trigger pulse is used as a long-time accumulation picture.

These modes are used for frame accumulation interlacing.

RESTART RESET MODE

R.R 1

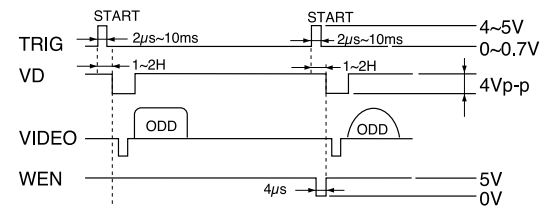

R.R 2

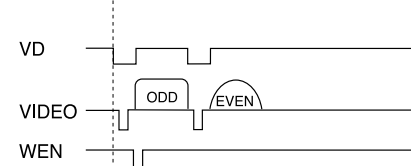

R.R 3

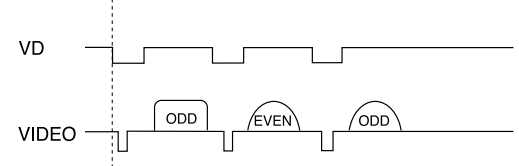

R.R 4

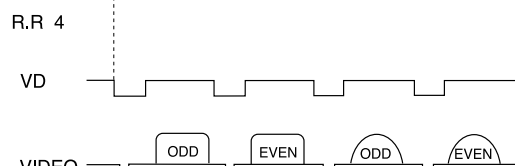

COMPARISON WITH SONY XC-711

		XC-003/P	XC-711/P
Pick up device		1/3"Hyper HAD IT CCD	2/3"HAD IT CCD
Sensing system		3CCD prism block(*:1)	1CCD RGB vertical
Lens mount		C mount	C mount
Horizontal resolution	NTSC/PAL	570TV lines/570TV lines	330TV lines/330TV lines
	RGB	756 pixels/739 pixels each	252 pixels/246 pixels each
Vertical resolution		485 lines/575 lines	485 lines/575 lines
RGB sync system		2Vp-p, 75 Ω	0.3Vp-p/2Vp-p, 75 Ω
Extrenal sync system		HD/VD, VS(*:2)	HD/VD, VS(*:3)
External trigger shutter		E-DONPISHA (*:4) Internal sync Restart Reset(*:4)	External sync Restart Reset
Shutter speed		Normal:1/100~1/10000sec. E-DONPISHA®:1/1000~1/12000sec. PAL~1/10000sec.	Normal:1/125~1/10000sec. PAL:1/60~
Dimensions		50(H) x 56(W) x 128(D)mm	50(H) x 56(W) x 149(D)mm

- * : 1. In some lenses, the color shading peculiar to a prism block may occur. Therefore, use an XC-003 lens (VCL-08WM/16WM/25WM) or a lens with a exit pupil distance of more than 100 mm.
2. VBS and Y/C signals are used as a monochromatic video output signal during external synchronization.
3. VBS and Y/C signals are used as a monochromatic video output signal during external synchronization, but they can be color-monitored by changing the internal setting of the camera.
4. The internal sync restart reset mode and E-DONPISHA® reset mode cannot be externally synchronized using an HD/VD signal or VS signal.

Long-Time Exposure

The long-time exposure up to 128 frames can be carried out at low-speed shutter mode at on-screen menu. The XC-003/003P automatically calculates the integration time corresponding to the frame numbers on the menu, and outputs continued frame images.

The long-time exposure also can be available with Restart Reset function. For this function, 2 trigger pulses are required; one for starting the integration, the other for ending it. Field or frame output is available by Restart Reset mode setting.

SPECIFICATIONS

	XC-003	XC-003P
Signal system	NTSC	PAL
Pick up device	1/3" Hyper HAD Interline Transfer CCD(x3)	
Picture elements	768(H) x 494(V)	752(H) x 582(V)
Video output elements	756(H) x 485(V)	739(H) x 575(V)
Cell size	6.35(H) x 7.4(V)μm	6.5(H) x 6.25(V)μm
Lens mount	C mount	
Flange back	17.526mm in air	
Video out	RGB, Y/C(9pin D-Sub), VBS(12pin/BNC), Sync(RGB):2Vp-p, 75 Ω	
Horizontal resolution	570TV lines, RGB:756pixels each	570TV lines, RGB:739pixels each
S/N ratio	59dB	58dB
Sensitivity	2000Lux(F5.6)	
Min.sensitivity	31Lux(F2.2, Gain+18dB, video out 100%level)	
Gain	0~18dB(1dB STEP)	
Sync system	Internal/External(auto)	
External sync	HD/VD, VS(Frequency deviation:±1%)	
Shutter speed	Normal shutter:1/100~1/10000sec.(8 steps) Low speed shutter:2~129 frame(1 frame each) E-DONPISHA: 1/1000~1/12000sec.(8 steps)	E-DONPISHA: 1/1000~1/10000sec.(7 steps) Restart Reset:1/100~1/10000sec.(8 steps)
External trigger input	H:4~5Vp-p, L:0~0.7Vp-p, positive polarity, High resepction pulse width:2μ~10msec.	
WEN output	5Vp-p, negative polarity(+/- changeable), High impedance termination	
Power requirements	DC12V(11.0~16.0V)/5.6W	
Dimensions	56(W) x 50(H) x 128(D)mm	
Weight	440g	
Regulations	FCC, UL, CSA, CE	
Operating temperature	-5~+45°C	
Storage temperature	-20~+60°C	
Shock resistance	490m/sec.(50G), 6 directions	
Vibration resistance	29.4m/sec.(3G), 11~200Hz,	
MTBF	19200Hrs(based on MIL-HDBK-217F)	

DIMENSIONS

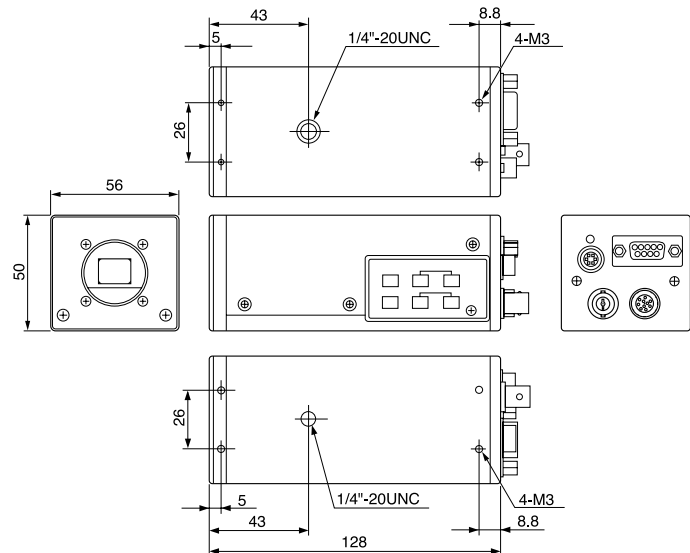

- Sony Electronics Inc. ISP(USA)
Itasca Office
San Jose Office
Park Ridge Office
- Sony of Canada Ltd.(CANADA)
- Sony Broadcast & Professional Europe
HQ
Germany
France
UK
Nordic
Italy
- Sony Corp. B&P Co. IVIS Marketing Dpt.(JAPAN)

1200 N. Arlington Heights Rd, MD-1118 Itasca, IL 60143-1291
3300 Zanker Rd, MS-SJ2B1 San Jose, CA 95134-1901
1 Sony Drive Park Ridge, NJ 07645
411 Gordon Baker Road, Willowdale, Ontario M2H 2S6

15, rue Floreal 75831 Paris Cedex 17, France
Hugo-Eckener-Str. 20, 50829 Kolin
15, rue Floreal 75831 Paris Cedex 17
The Heights, Brooklands, Weybridge, Surrey KT13 0XW
Per Albin Hanssons vag 20 S-214 32 Malmö Sweden
Via Galileo Galilei 40 I-20092 Cinisello Balsamo, Milano

(TEL:+1-630-773-7604) (FAX:+1-630-773-7605)
(TEL:+1-408-955-5623) (FAX:+1-408-955-5630)
(TEL:+1-201-358-4173) (FAX:+1-201-358-4401)
(TEL:+1-416-499-1414) (FAX:+1-416-497-1774)

(TEL:+33-1-40-87-35-11) (FAX:+33-1-40-87-35-17)
(TEL:+49-221-5966-322) (FAX:+49-221-5966-491)
(TEL:+33-1-49-45-41-62) (FAX:+33-1-47-31-13-57)
(TEL:+44-990-331122) (FAX:+44-1932-817011)
(TEL:+46-40-190-800) (FAX:+46-40-190-450)
(TEL:+39-2-618-38-431) (FAX:+39-2-618-38-402)
(FAX:+81-462-27-2347)