

BNC — 75 Ohm

BNC 75 Ohm

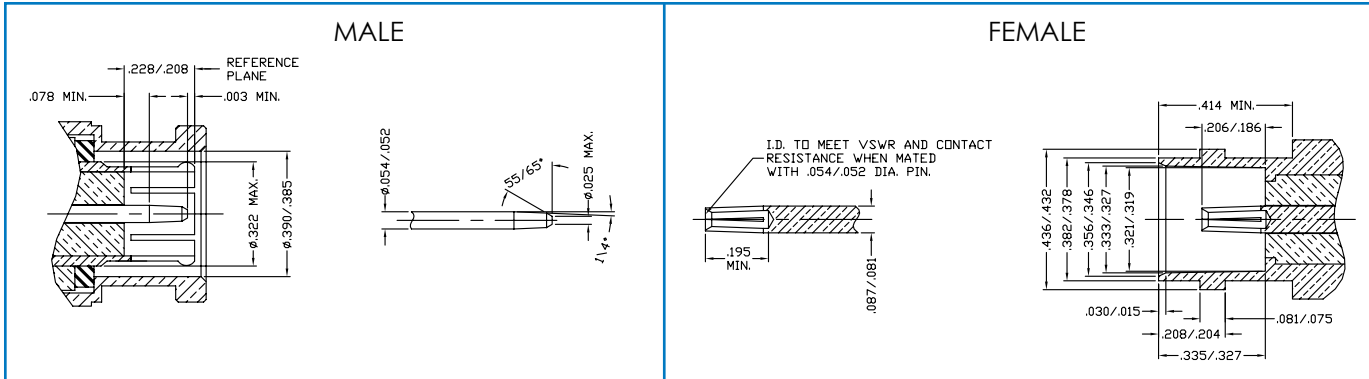

SPECIFICATIONS	CABLE GROUPS	
<p>ELECTRICAL SPECIFICATIONS IMPEDANCE: 75 Ω WORKING VOLTAGE RATING: 500 VRMS FREQUENCY RANGE: 0-2 GHz</p> <p>MECHANICAL SPECIFICATIONS MATING: 2-STUD BAYONET LOCK COUPLING INTERFACE: MIL-STD-348 CABLING: CLAMP, CRIMP, COMPRESSION AND TWIST-ON</p> <p>PLATING G - GOLD N - NICKEL S - SILVER TP - THERMOPLASTIC</p> <p>DIELECTRIC MATERIAL D - DELRIN P - POLYPROPYLENE T - TEFLON TP - THERMOPLASTIC</p>	GRP	FOR THESE CABLE TYPES
	D	RG-59, 59A, 59B, 62, 62A, 62C/U; ALPHA 9059, 9062, 9830, 9840, 9845; BELDEN 8221, 8241, 9169, 9204, 9228; CANARE LV-61S; COMMSCOPE 5550, 5555, 5560, 5563
	D1	BELDEN 1426A, 1505A, 8212, 8241F, 9100, 9110, 9165, 9171, 9240, 9259, 9265, 9274, 9275, 9659, YR2393D; COMMSCOPE 5553, 5565, 5552, 5550, 5567, 5571
	D2	BELDEN 8279, 8279A, 9209, 9209A, 82241, 88241; COMMSCOPE 2041K, 7573
	D3	RG-59/U TYPE; BELDEN 1506A, 1825A, 1826A, 82108, 89108, 89259; COMMSCOPE 2045, 2045V, 2065V
	G	ALPHA 9807, 9808, 9813; BELDEN 8281, 9141, 9231, 88281; COMMSCOPE 2527K, 7501, 7503, 7505, 7506; CANARE LV-775; WESTERN ELECTRIC WE724, WE728, WE729
	J	BELDEN 1164A, 1164B, 1167B, 1263A, 1406B, 1407B, 1417B, 1818B, 1865A, 8218; COMMSCOPE 7537, 753603, 753604, 753605; RAYCHEM EPD 0810
	K	COMMSCOPE 735, 73501, 73501P
	Q	RG-6/U TYPE; BELDEN 1694A, 9248; COMMSCOPE 5715, 5729, 5765
	Q1	RG-6/U TYPE PLENUM; BELDEN 1695A, 82120, 82248, 87120, 89120, 89248; COMMSCOPE 2278, 2278V, 2279, 2279K, 2279V
	R	RG-11/U TYPE; BELDEN 8213, 8238, 8261, 9011, 9292; COMMSCOPE 3247, 5901, 5903, 5908, 5909, 5916, 5916R, 5918
	S	RG-161, 179, 179A, 187, 187A/U; BELDEN 1520A, 1521A, 1522A, 9221; COMMSCOPE 15-55340



PHOTOS FOR REFERENCE ONLY, SHOWN AT 100% ACTUAL SIZE.

PART #	FIG	DESCRIPTION	CBL GRP	NOTES	REPLACES OR EQUIVALENT TO	PLATING			RECOMMENDED TOOL
						BDY	P/C	DIE	
RFB-1701-D	1	MALE CLAMP	D	FOR RG-59/U	HUBER SUHNER 11 BNC-75-4-2	N	G	T	
RFB-1701-G	1	MALE CLAMP	G	BELDEN 8281		N	S	T	
RFB-1704-D	2	MALE COMPRESSION CRIMP	D	FOR RG-59/U	BLACK BAND	N	G	T	RFA-4004-20
RFB-1704-Q	2	MALE COMPRESSION CRIMP	Q	FOR RG-6/U	RED BAND	N	G	T	RFA-4004-20
RFB-1705	3	MALE TWIST-ON	D	FOR RG-59/U		N	S	D	
RFB-1706-9	4	MALE CRIMP	D	QUICK DISCONNECT FOR RG-59/U		N	G	D	RFA-4009-203

75-OHM BNC CONNECTORS AND IN-SERIES ADAPTERS — continued

BNC 75 Ohm

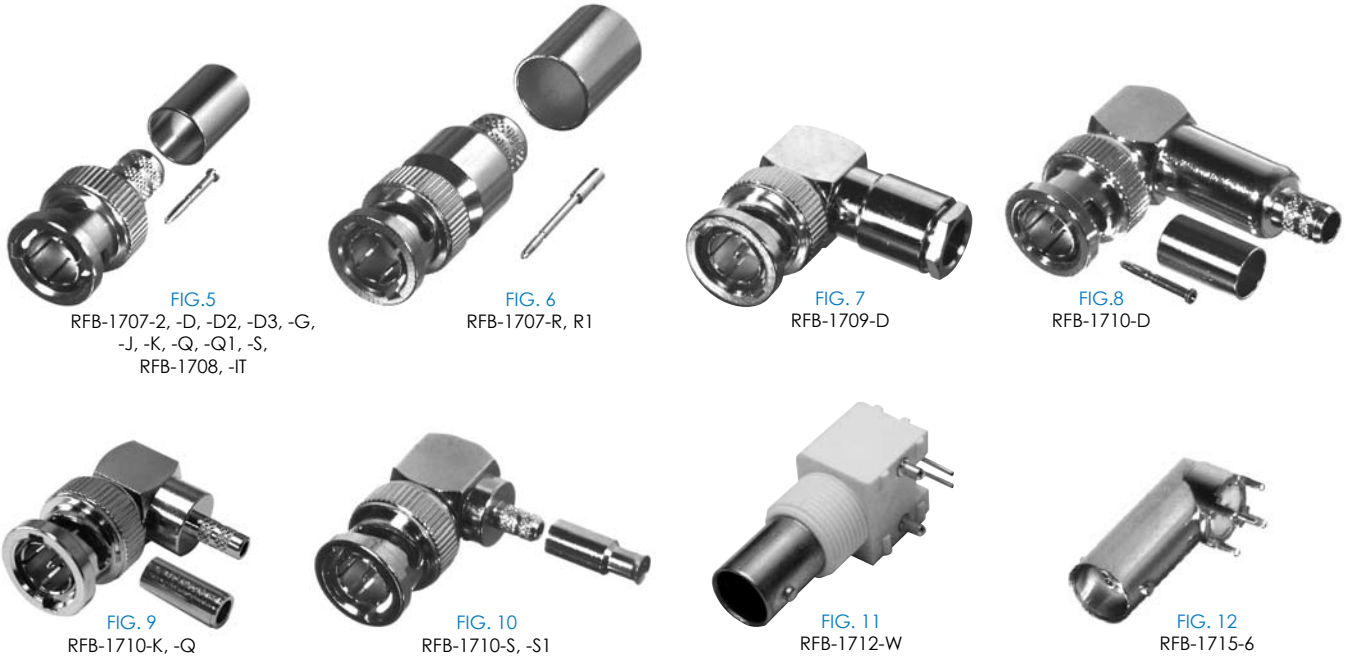

FIG. 5
RFB-1707-2, -D, -D2, -D3, -G,
-J, -K, -Q, -Q1, -S,
RFB-1708, -IT

FIG. 6
RFB-1707-R, R1

FIG. 7
RFB-1709-D

FIG. 8
RFB-1710-D

FIG. 9
RFB-1710-K, -Q

FIG. 10
RFB-1710-S, -S1

FIG. 11
RFB-1712-W

FIG. 12
RFB-1715-6

PHOTOS FOR REFERENCE ONLY, SHOWN AT 100% ACTUAL SIZE.

PART #	FIG	DESCRIPTION	CBL GRP	NOTES	REPLACES OR EQUIVALENT TO	PLATING			RECOMMENDED TOOL
						BDY	P/C	DIE	
RFB-1707-2	5	MALE CRIMP	D	FOR RG-59/U	UG-1789/U	N	G	D	RFA-4009-203
RFB-1707-D	5	MALE CRIMP	D, D1	FOR RG-59/U	UG-1789/U, KINGS 2025-59-9	N	G	T	RFA-4009-203
RFB-1707-D2	5	MALE CRIMP	D2	FOR BELDEN 8279	KINGS 2025-38-9	N	G	T	RFA-4009-203
RFB-1707-D3	5	MALE CRIMP	D3	FOR RG-59/U TYPE	KINGS 2025-53-9	N	G	T	RFA-4009-203
RFB-1707-G	5	MALE CRIMP	G	FOR BELDEN 8281	KINGS 2025-55-9	N	G	T	RFA-4005-308
RFB-1707-J	5	MALE CRIMP	J	FOR BELDEN 8218	KINGS 2025-47-9	N	G	T	RFA-4005-307
RFB-1707-K	5	MALE CRIMP	K	FOR COMMSCOPE 735	KINGS 2025-44-9	N	G	T	RFA-4005-307
RFB-1707-Q	5	MALE CRIMP	Q	FOR RG-6/U	KINGS 2025-79-9	N	G	T	RFA-4005-308
RFB-1707-Q1	5	MALE CRIMP	Q1	FOR RG-6/U TYPE	KINGS 2025-89-9	N	G	T	RFA-4005-308
RFB-1707-R	6	MALE CRIMP	R	FOR RG-11/U	HUBER SUHNER 11 BNC-75-7-5	N	G	T	RFA-4009-205
RFB-1707-R1	6	MALE CRIMP	R1	FOR RG-11/U TYPE	18 AWG CENTER COND. CABLE	N	G	T	RFA-4009-205
RFB-1707-S	5	MALE CRIMP	S	FOR RG-179/U	KINGS 2025-57-9	N	G	T	RFA-4005-307
RFB-1708	5	MALE CRIMP	G	FOR BELDEN 8281	KINGS 2025-58-9	N	G	D	RFA-4005-308
RFB-1708-IT	5	MALE CRIMP	G	FOR BELDEN 8281	KINGS 2025-58-9	S	G	T	RFA-4005-308
RFB-1709-D	7	MALE RIGHT ANGLE CLAMP	D	FOR RG-59/U	HUBER SUHNER 16 BNC-75-4-2	N	G	T	
RFB-1710-D	8	MALE RIGHT ANGLE CRIMP	D	FOR RG-59/U	AMPHENOL 31-71010	N	G	T	RFA-4009-203
RFB-1710-K	9	MALE RIGHT ANGLE CRIMP	K	FOR COMMSCOPE 735	KINGS 2026-17-9	N	G	T	RFA-4005-305
RFB-1710-Q	9	MALE RIGHT ANGLE CRIMP	Q	FOR RG-6/U		N	G	T	RFA-4005-308
RFB-1710-S	10	MALE RIGHT ANGLE CRIMP	S	FOR RG-179/U	HUBER SUHNER 16 BNC-75-2-3	N	G	T	RFA-4005-307
RFB-1710-S1	10	MALE RIGHT ANGLE CRIMP	S	FOR RG-179/U DOUBLE SHIELD		N	G	T	RFA-4005-307
RFB-1712-W	11	FEMALE R/A LO-PROFILE PCB MOUNT		WITH POST LEGS, WHITE	Amphenol 31-71052	N/TP	G	PP	
RFB-1715-6	12	FEMALE RIGHT ANGLE PCB MOUNT		HIGH FREQ., LONG BODY, DIECAST ZINC		N	G	T	



FIG. 13
RFB-1715-11



FIG. 14
RFB-1716



FIG. 15
RFB-1716-1



FIG. 16
RFB-1717, -Q, -S



FIG. 17
RFB-1720



FIG. 18
RFB-1722



FIG. 19
RFB-1724, -K, -Q, -S



FIG. 20
RFB-1730



FIG. 21
RFB-1730-3, -4



FIG. 22
RFB-1732



FIG. 23
RFB-1733



FIG. 24
RFB-1734, -2

PHOTOS FOR REFERENCE ONLY, SHOWN AT 100% ACTUAL SIZE.

PART #	FIG	DESCRIPTION	CBL GRP	NOTES	REPLACES OR EQUIVALENT TO	PLATING			RECOMMENDED TOOL
						BDY	P/C	DIE	
RFB-1715-11	13	FEMALE VERTICAL PCB MOUNT		4 LEGS ON .400" CENTERS	HUBER SUHNER 82 BNC-75-0-2	N	G	T	
RFB-1716	14	FEMALE BULKHEAD		FRONT MOUNT WITH D-FLAT, DIECAST ZINC	AMPHENOL 31-71004	N	G	D	
RFB-1716-1	15	FEMALE BULKHEAD		FRONT MOUNT WITH D-FLAT, INSULATED	AMPHENOL 31-10-75	N	G	TP	
RFB-1717	16	FEMALE CRIMP BULKHEAD	D	REAR MOUNT WITH D-FLAT & O-RING, FOR RG-59/U	AMPHENOL 31-71011-RFX	N	G	D	RFA-4009-203
RFB-1717-Q	16	FEMALE CRIMP BULKHEAD	Q	REAR MOUNT WITH D-FLAT & O-RING, FOR RG-6/U	KINGS 2022-29-9	N	G	T	RFA-4005-308
RFB-1717-S	16	FEMALE CRIMP BULKHEAD	S	REAR MOUNT WITH D-FLAT & O-RING, SOLDER ONLY PIN, FOR RG-179/U	AMPHENOL 31-70016	N	G	T	RFA-4009-204
RFB-1720	17	FEMALE CLAMP	D	FOR RG-59/U	UG-261C/U	N	S	T	
RFB-1722	18	FEMALE TWIST-ON	D	FOR RG-59/U		N	S	D	
RFB-1724	19	FEMALE CRIMP	D	FOR RG-59/U		N	G	D	RFA-4009-203
RFB-1724-K	19	FEMALE CRIMP	K	FOR COMMSCOPE 735		N	G	T	RFA-4005-307
RFB-1724-Q	19	FEMALE CRIMP	Q	FOR RG-6/U		N	G	T	RFA-4005-308
RFB-1724-S	19	FEMALE CRIMP	S	FOR RG-179/U	AMPHENOL 31-71014-RFX	N	G	T	RFA-4009-204
RFB-1730	20	T ADAPTER		BNC MALE TO DOUBLE BNC FEMALE	AMPHENOL 31-70036	N	G	T	
RFB-1730-3	21	F ADAPTER		BNC MALE TO DOUBLE BNC FEMALE		N	G	T	
RFB-1730-4	21	F ADAPTER		BNC MALE TO DOUBLE BNC FEMALE W/ INTERNAL 75 OHM RESISTORS (VIDEO SPLITTER)		N	G	D	
RFB-1732	22	RIGHT ANGLE ADAPTER		BNC MALE TO BNC FEMALE	AMPHENOL 31-9-75	N	G	T	
RFB-1733	23	BARREL ADAPTER		BNC MALE TO BNC MALE	AMPHENOL 31-218-75	N	G	T	
RFB-1734	24	BARREL ADAPTER		BNC FEMALE TO BNC FEMALE	AMPHENOL 31-219-75	N	G	T	
RFB-1734-2	24	BARREL ADAPTER		BNC FEMALE TO BNC FEMALE		S	G	T	



FIG. 25
RFB-1735, -I



FIG. 26
RFB-1745



FIG. 27
RFB-1750



FIG. 28
RFB-1760

PHOTOS FOR REFERENCE ONLY, SHOWN AT 100% ACTUAL SIZE.

PART #	FIG	DESCRIPTION	CBL GRP	NOTES	REPLACES OR EQUIVALENT TO	PLATING			RECOMMENDED TOOL
						BDY	P/C	DIE	
RFB-1735	25	FEMALE BULKHEAD ADAPTER		DOUBLE BNC FEMALE WITH D-FLAT & O-RING	AMPHENOL 31-70020	N	G	T	
RFB-1735-I	25	FEMALE BULKHEAD ADAPTER		DOUBLE BNC FEMALE WITH D-FLAT, ISOLATED	AMPHENOL 31-4803-75	N	G	T	
RFB-1745	26	STRAIGHT ADAPTER		BNC FEMALE TO 1/4X24 STUD, FOR KENWOOD TK240, TK340	MIDLAND 70-1034	N	S	T	
RFB-1750	27	MALE TERMINATION		75 OHM 1/2 WATT		N	G	D	
RFB-1760	28	FEMALE CRIMP	D	WALLPLATE FLUSH MOUNT FOR RG-59/U		N	G	D	RFA-4009-203

2-Blade Coaxial Stripper
for compression connectors only



RFA-4004-30

Compression Crimp Handle, 3-in-One Tool
for compression connectors only



RFA-4004-20

CONNECTOR MATING TIPS

- Before joining connectors, inspect mating surfaces for dirt, dust, debris and bent or broken contacts.
- When mating connectors, always turn the coupling nut rather than the body.
- In general, the tighter you make the coupling mechanism, the better the performance. However, many connectors are destroyed by over-torquing the coupling nut. Paired connectors tend to be inductive due to gaps of various types.
- Use a torque wrench for mating threaded adapters or cable assembly terminations when the reciprocal connector is mounted to equipment. Over torquing of plugs can damage the instrument mounted jack and the adapter or cable connector. This will also void most equipment warranties.